

VEHICLE PROFILE

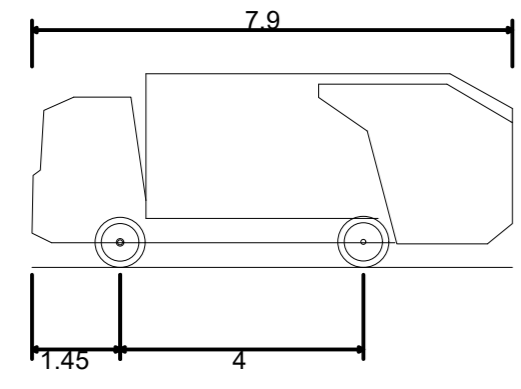

DB32 Refuse Vehicle	7.900m
Overall Length	2.400m
Overall Width	3.183m
Overall Body Height	0.388m
Min Body Ground Clearance	2.400m
Max Track Width	6.00s
Lock-to-lock time	9.625m
Curb to Curb Turning Radius	

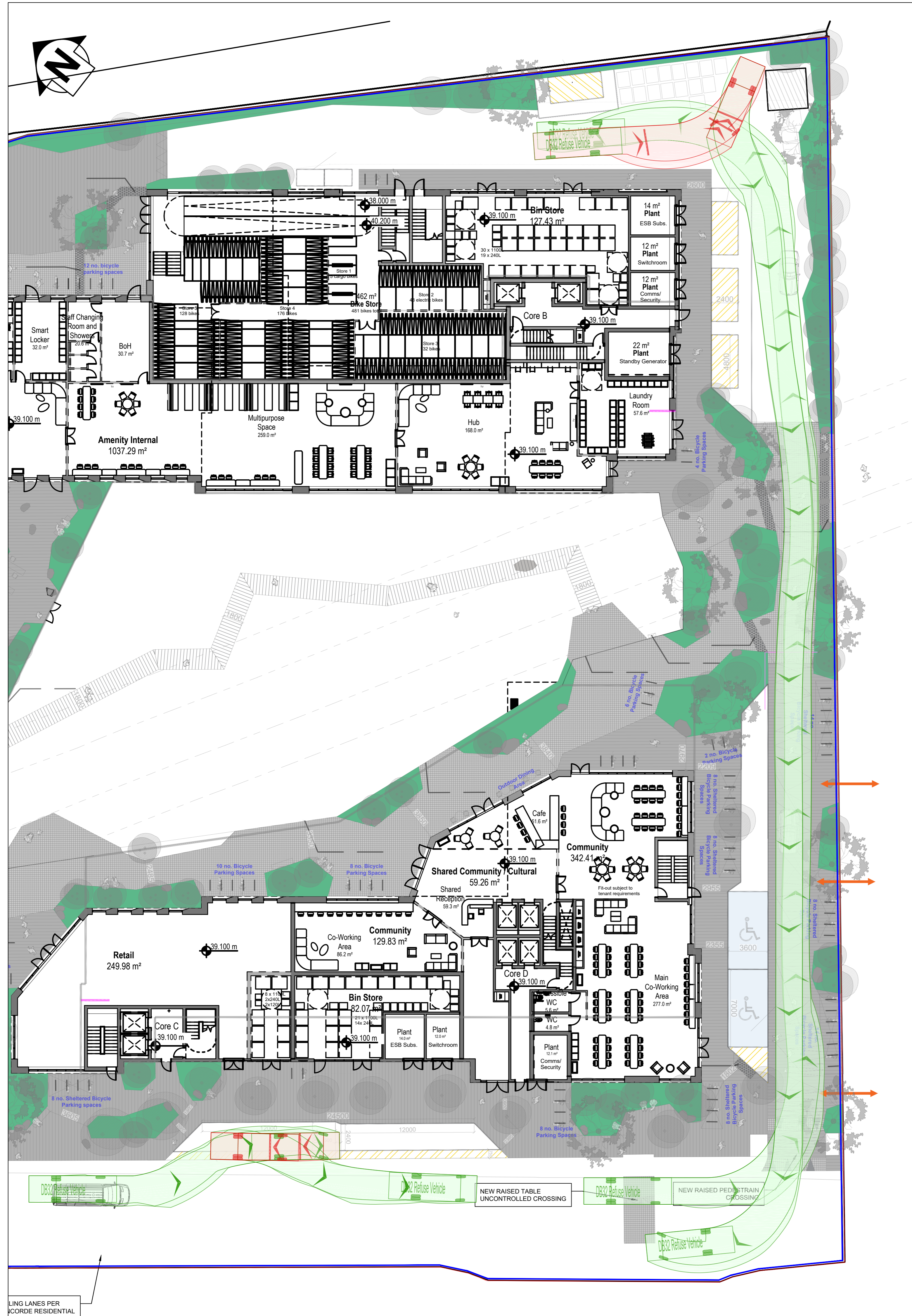

AUTOROUTE TRACKING - REFUSE VEHICLE

SCALE @ A0: 1:200
SCALE @ A2: 1:400

VEHICLE PROFILE

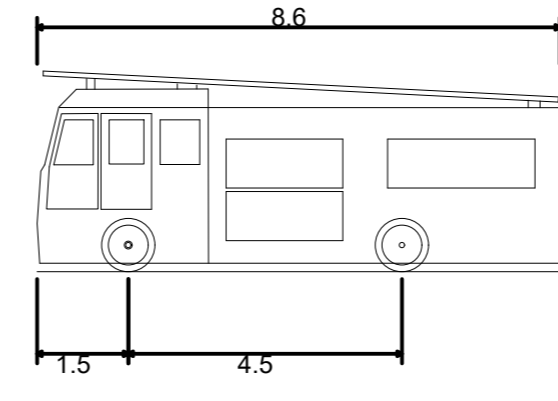

Dublin Fire Brigade	8.600m
Overall Length	2.500m
Overall Width	3.300m
Overall Body Height	0.140m
Min Body Ground Clearance	2.500m
Track Width	4.00s
Lock-to-lock time	7.750m
Curb to Curb Turning Radius	



AUTOROUTE TRACKING - FIRE TENDER

SCALE @ A0: 1:200
SCALE @ A2: 1:400

NOTES

- THIS DRAWING IS TO BE READ IN CONJUNCTION WITH ALL ENGINEERS & ARCHITECT'S DRAWINGS FIGURED DIMENSIONS ONLY (NOT SCALING) TO BE USED, WHERE A CONFLICT OF INFORMATION EXISTS OR IF IN ANY DOUBT - ASK.
- CONSULTANTS TO BE INFORMED IMMEDIATELY OF ANY DISCREPANCIES BEFORE WORK PROCEEDS.

PL2	14.10.23	ISSUED FOR PLANNING	AD
ISSUE	DATE	DESCRIPTION	BY
Project Engineer: JC		Project Director: JC	

BM STAGE **PLANNING**

BM
BAIRETT MAINDY
Consulting Engineers, Civil, Structural, Project Management. E-mail: bmca@bmca.ie Web: www.bmca.ie

The Institution of Structural Engineers
ACEI
The Institution of Structural Engineers

CLIENT **MALCLOSE LTD.**

PROJECT TITLE	PROJECT NO.
GOWAN HOUSE	22.219

REFERENCE	SUITABILITY	REVISION

DRAWING TITLE **AUTOROUTE TRACKING - REFUSE VEHICLE & FIRE TENDER**

DRAWING REFERENCE	STATUS	REVISION
GWH-BMD-ZZ-00-DR-C-1040	S0	PL2